

**SPECIFICATIONS**

**GENERAL:**

The surface drainage system shall be Food Safe Area Drain - Square Top, complete with strainer basket, as manufactured by FoodSafe Drains.

**MATERIALS:**

T304 Stainless Steel or T316 Stainless Steel

**LOAD CLASS:**

Load Class E

**INSTALLATION:**

The Food Safe Area Drain - Square Top shall be installed in accordance with the manufacturer's installation instructions and recommendations.

TYPICAL PROFILE OF A FOOD SAFE AREA DRAIN - SQUARE TOP SYSTEM

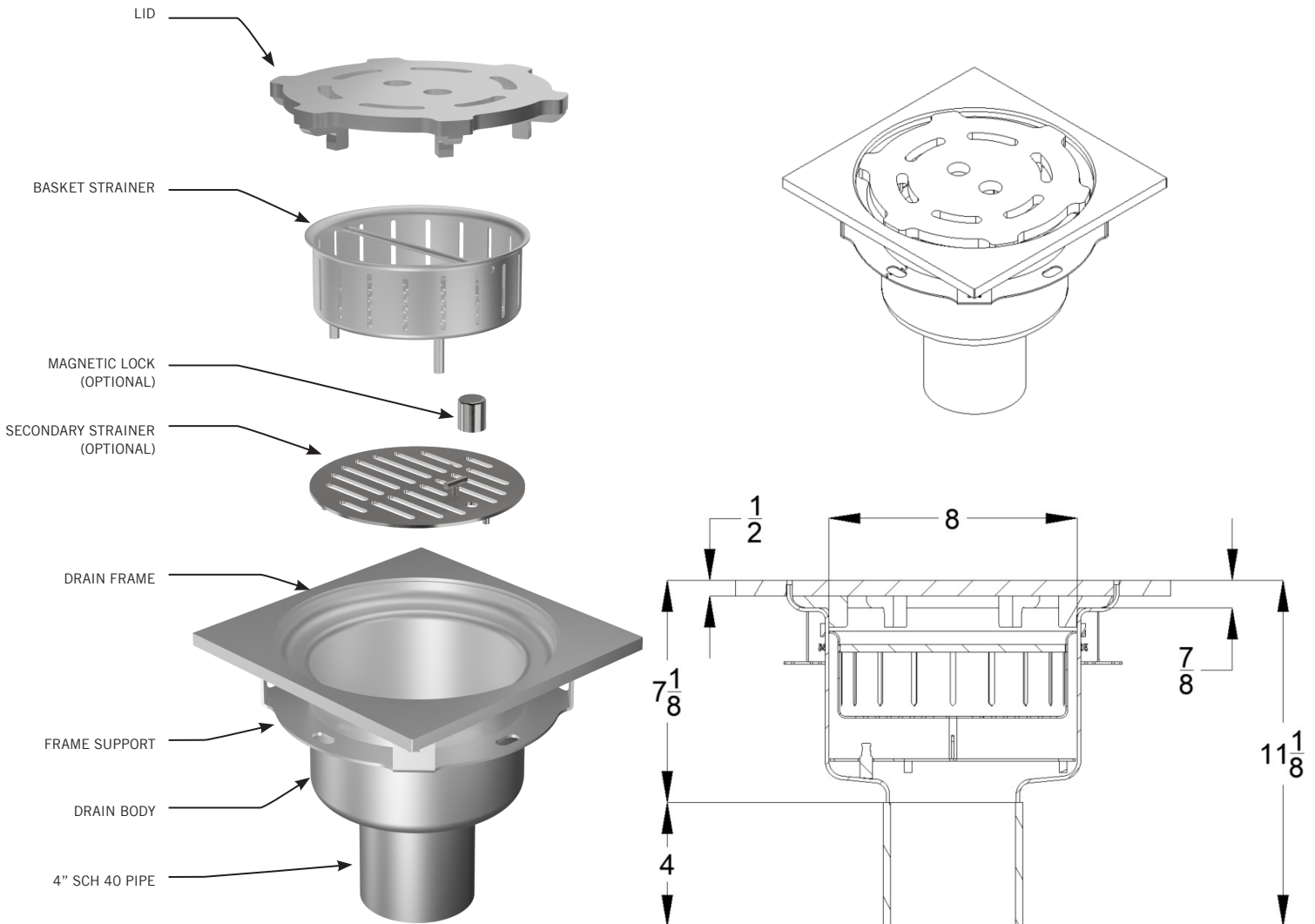

**MEASUREMENTS**

DESCRIPTION	DRAIN TOP ID INCHES	DRAIN OD INCHES	LID DIAMETER INCHES	LID HEIGHT INCHES	OUTLET DIAMETER INCHES	OUTER EDGE INCHES
FSD AREA - SQUARE	8	10 1/2	9 3/4	1 1/2	3 or 4	14

OPTIONALLY, NON-MAGLOCK DESIGN ALSO AVAILABLE.  
SPECIFYING ENGINEER IS RESPONSIBLE FOR CONCRETE ENCASEMENT AND REINFORCING BASED UPON APPLICATION AND LOCAL CODES.  
SLOT DRAIN SYSTEMS RESERVES THE RIGHT TO CHANGE THE PRODUCT AND SPECIFICATIONS WITHOUT NOTICE